

WORK HEIGHT	3.41	3.88	4.34	4.81	5.27	5.73	6.20	6.66	7.13	7.59	8.05	8.52	8.98	9.45	9.91	10.37	10.84	11.30	11.77	12.23	12.69	13.16	13.62	14.09		
TOWER HEIGHT	2.66	3.13	3.59	4.06	4.52	4.98	5.45	5.91	6.38	6.84	7.30	7.77	8.23	8.70	9.16	9.63	10.10	10.56	11.03	11.49	11.96	12.42	12.89	13.35		
PLATFORM HEIGHT	1.41	1.88	2.34	2.81	3.27	3.73	4.20	4.66	5.13	5.59	6.05	6.52	6.98	7.45	7.91	8.37	8.84	9.30	9.77	10.23	10.69	11.16	11.62	12.09		
PARTS LIST																										
CASTOR	4	4	4	4	4	4	4	4	4	4	4	4	4	4	4	4	4	4	4	4	4	4	4	4	4	
ADJUSTABLE LEG	4	4	4	4	4	4	4	4	4	4	4	4	4	4	4	4	4	4	4	4	4	4	4	4	4	
3 RUNG PLAIN FRAME	2	1	1	1	1	1	1	1	1	1	1	1	1	1	1	1	1	1	1	1	1	1	1	1	1	
3 RUNG LADDER FRAME	2	1	1	1	1	1	1	1	1	1	1	1	1	1	1	1	1	1	1	1	1	1	1	1	1	
4 RUNG PLAIN FRAME	1	1	1	1	1	1	1	1	1	1	1	1	1	1	1	1	1	1	1	1	1	1	1	1	1	
4 RUNG LADDER FRAME	1	1	1	1	1	1	1	1	1	1	1	1	1	1	1	1	1	1	1	1	1	1	1	1	1	
5 RUNG PLAIN FRAME	1	1	1	1	1	1	1	1	1	1	1	1	1	1	1	1	1	1	1	1	1	1	1	1	1	
5 RUNG LADDER FRAME	1	1	1	1	1	1	1	1	1	1	1	1	1	1	1	1	1	1	1	1	1	1	1	1	1	
DIAGONAL BRACE	2	2	4	4	4	6	8	8	8	10	10	12	12	14	14	16	18	18	20	22	22	24	24	24	24	
HORIZONTAL BRACE	6	6	6	6	6	10	10	10	10	10	10	10	10	10	10	10	10	10	10	10	10	10	10	10	10	
PLAIN PLATFORM	1	1	1	1	1	1	1	1	1	1	1	1	1	1	1	1	1	1	1	1	1	1	1	1	1	
TRAPDOOR PLATFORM	1	1	1	1	1	1	1	1	1	1	1	1	1	1	1	1	1	1	1	1	1	1	1	1	1	
STABILISER																										
JUMBO STABILISER																										
TOEBOARD ASSEMBLY	1	1	1	1	1	1	1	1	1	1	1	1	1	1	1	1	1	1	1	1	1	1	1	1	1	
TOWER WEIGHT (kgs)																										
2.5m LENGTH	104	112	119	127	135	143	151	159	167	175	183	191	199	207	215	223	231	239	247	255	263	271	279	287		



A6164/2

The platform levels marked * indicate that these platforms and handrails are repositioned.

All frames can be used as uppers or lowers, simply place the platform on the third rung below the top of the tower and the correct guardrail height is achieved. The number of plain and trapdoor platforms in the tower kit list is sufficient to assemble and dismantle the tower by the 3T method.

KLIK LADDER FRAME SCAFFOLD TOWER DOUBLE WIDTH KIT LIST AVAILABLE IN THREE LENGTHS: 2m, 2.5m or 3m

KLIK ALUMINIUM SCAFFOLD TOWER EQUIPMENT GENERAL SAFETY RULES

- Check instructions before use. Mobile access and working towers may only be erected and dismantled by persons familiar with these instructions for erection and use.
- Do not use any scaffold tower which is damaged, which has not been properly erected, which is not firm and stable, and which has any missing or damaged parts.
- Do not erect a scaffold tower on unstable ground or objects, such as loose bricks, boxes or blocks. Only a sound rigid footing must be used.
- Ensure that the scaffold tower is always level and the adjustable legs are engaged. Check that you have taken all necessary precautions to prevent the tower being moved, or rolling away. Always apply all castor brakes or use base plates.
- Ensure that all frames, braces and platforms are firmly in place and that all locking hooks are functioning correctly. Ensure that all frame locking clips are engaged. If any are missing, replace them.
- Ensure that the scaffold tower is within the maximum platform height as stated, and that appropriate stabilizers are fitted.
- Outdoor scaffold towers should, wherever possible, be secured to a building or other structure. It is good practice to tie in all scaffold towers of any height, especially when they are left unattended, or in exposed or windy conditions.
- A scaffold tower must not be used in winds stronger than 7.7 meters per second. Beaufort Scale 4. Be cautious if erecting or using the tower in open places, such as hangars or unclad buildings. In such circumstances the wind forces can be increased, as a result of the funnelling effect.
- Do not use sheeted towers.
- Do not erect or use a scaffold tower near uninsulated, live or energised electrical machinery or circuits, or near machinery in operation.
- If an overhead hazard exists head protection should be worn.
- Do not lean ladders against the tower, or climb the outside of the tower. Whatever your intended access system, it should only be used inside the tower.
- Never climb horizontal or diagonal braces. Do not gain access to, or descend from the working platform other than by the intended access system.
- Do not work from ladders or stairways, they are a means of access only.
- Guardrails and toeboards must be fitted to the working platforms.
- Never jump on to or off platforms.
- Do not exceed the safe working load of the platform or structure by accumulating debris, material or tools on platforms as these can be a significant additional load.
- If you must move a tower, remove all materials and personnel. When moving a scaffold tower force must always be applied to the base. The tower should only be moved manually on firm, level ground which is free from obstacles. Normal walking speed should not be exceeded during relocation. The ground over which a tower is moved should be capable of supporting the weight of the structure.
- Should you require additional platform height, add further frames. NEVER extend your adjustable legs to achieve extra height, these are for levelling only. NEVER use a ladder or other objects on the platform to achieve additional height.
- It is not permissible to attach and use hoisting facilities on towers, unless specifically provided for by the manufacturer.
- It is not permissible to attach bridging sections between a scaffold tower and a building. Refer to the tower manufacturer.
- ALWAYS TAKE CARE OF ALUMINIUM SCAFFOLD TOWER EQUIPMENT. REMEMBER YOUR SAFETY DEPENDS ON THE SAFE ERECTION AND USE OF THE EQUIPMENT. RESPECT IT.

MAINTENANCE RULES

- Ensure that the scaffold tower is kept clean, especially the spigots and sockets. These should fit together with ease and be secured by an interlock clip.
- Check frames and braces, adjustable legs and boards for paint, grit, burrs etc. Remove any foreign substance with a light wire brush. Check no slip hazard exists on the platform.
- Where brace, ladder and platform hooks attach to the frames ensure that the frame rungs are kept clean.
- Ensure that all locking hooks function correctly. If necessary, lubricate with a light oil.
- The inside diameter of all hooks should be kept clean to ensure they fit to other components without being forced.
- If in any doubt about the proper use and maintenance of the scaffold tower equipment, consult the manufacturer.
- Do not misuse or abuse the scaffold tower with heavy objects, hammers etc. Do not throw components in and out of vehicles, or to the ground when the tower is being dismantled. Such abuse may reduce the structural integrity of the scaffold tower.
- Under no circumstances use a scaffold tower which is damaged, has not been properly erected, is not rigid and which has any missing parts.
- REMEMBER YOUR SAFETY DEPENDS ON THE SAFE ERECTION AND USE OF THIS EQUIPMENT, RESPECT IT.

USE OF STABILIZERS

Stabilizers increase the EFFECTIVE BASE dimensions and improve the STABILITY of the tower.

Position the stabilizers symmetrically to obtain the MAXIMUM BASE DIMENSION.

Maximum platform heights for free standing towers are based on the base to height ratio of 3:1 outdoors and 3.5:1 indoors. When moving a tower with stabilizers the height to base ratio must not exceed 2.5:1.

OPTIMUM BASE DIMENSION	MAX HEIGHTS	STABILIZER TYPE
DOUBLE WIDTH OR STEP TOWER		
Double Width	2.34M	NONE
4.2M	5.13M	STANDARD
4.9M	10.23M	TELESCOPIC
5.4M	12.1M	LARGE

Fax: 020 8525 8687 BENTS PLANT HIRE LIMITED Tel: 020 8525 8686
 Email: sales@bentsplant.co.uk 68-82 Digby Road, London E9 6HX Web: www.bentsplant.co.uk

KLIK DOUBLE WIDTH LADDER FRAME ERECTION INSTRUCTION MANUAL

TUV CERTIFIED QUALITY SYSTEM TO ISO9001:2000

GS PRODUCT APPROVAL TO BS.EN.1004 3 8/12 XXXD

COMPONENTS

- Horizontal Brace
2M black/green/red
2.5M black/green/yellow
3M black/green/blue

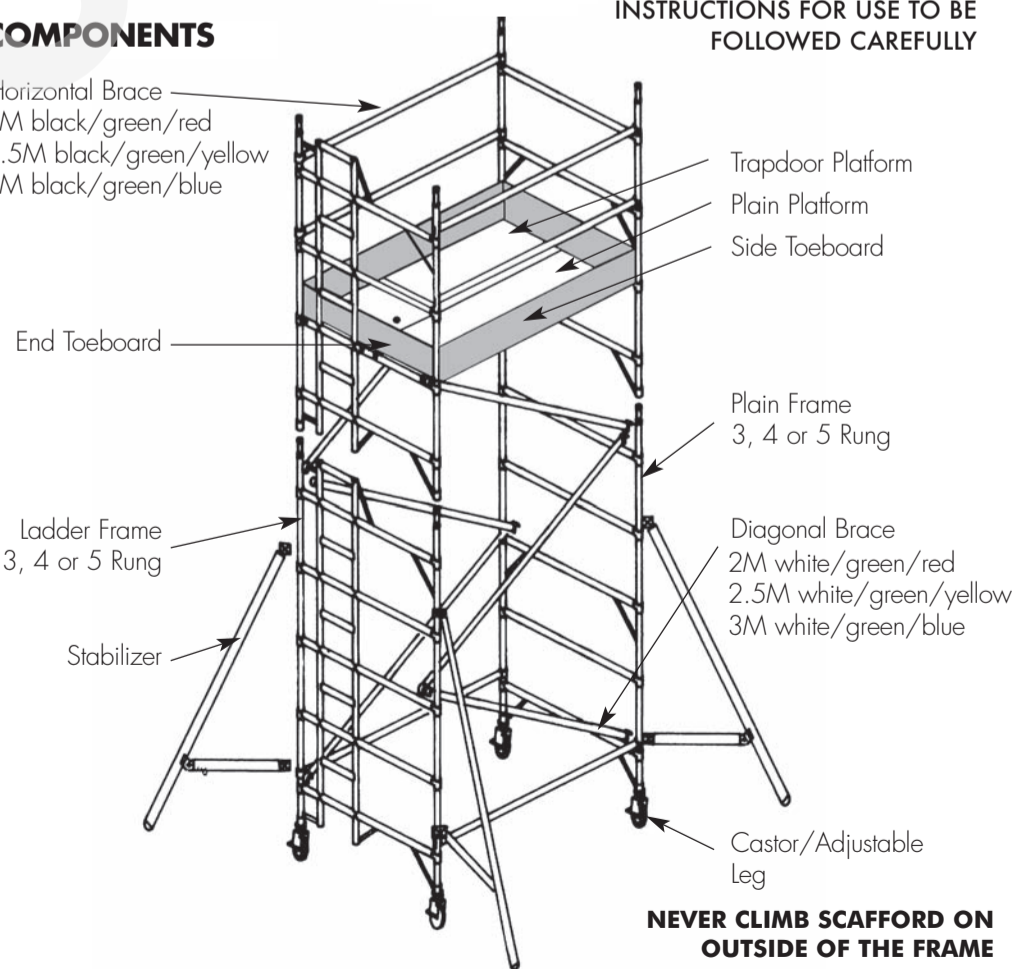

INSTRUCTIONS FOR USE TO BE FOLLOWED CAREFULLY

NEVER CLIMB SCAFFOLD ON OUTSIDE OF THE FRAME

MAX SAFE WORKING LOAD FOR STRUCTURE 750KG
 MAX SAFE WORKING LOAD FOR PLATFORM 250KG

[Web: www.bentsplant.co.uk](http://www.bentsplant.co.uk) [Email: sales@bentsplant.co.uk](mailto:sales@bentsplant.co.uk)

KLIK DOUBLE WIDTH LADDER FRAME ERECTION INSTRUCTION MANUAL



1 Insert two adjustable legs and castors into frame.

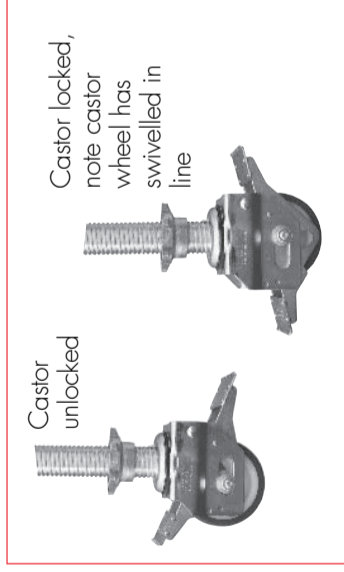

2



3 Klik in two horizontal braces to vertical member of the frame, as low down as possible.



4 Klik in diagonal braces, starting at the bottom rung. Braces should be added in a continuous pattern. When fitting a full intermediate work platform it is permissible to interrupt the continuous pattern.



5 Fit plain platform on appropriate rung of frame. See lower kit guide for illustration. This will indicate which rung to fit trapdoor platform depending on final lower height.

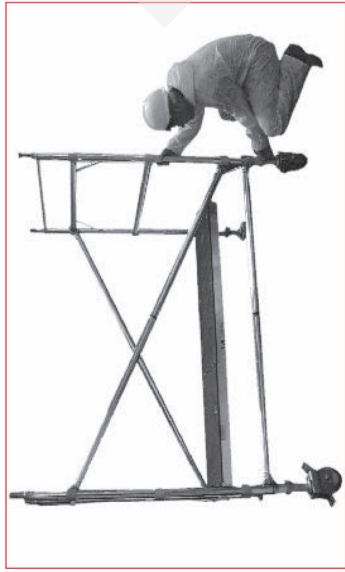

6 Lock castors and level tower.



7 Fit four handrail braces, two on outside and two on mid rung of frame as shown, on lower levels these may not be required.



8 To add further frames, stand on platform ensuring the ladder frames are in line.



9 After adding frames always engage interlock clips.



10 Klik in diagonal braces to continue in a regular pattern. Double width towers always have diagonal braces either side of the tower opposing each other as illustrated.

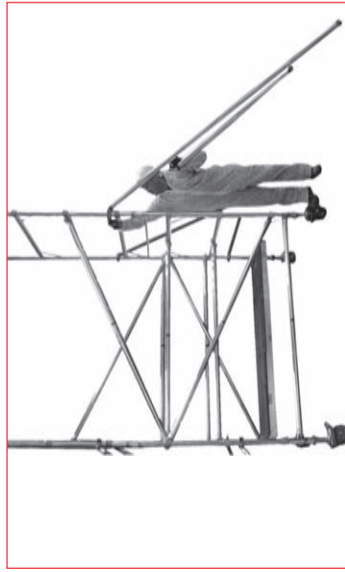

11 Secure stabilisers as soon as possible to increase tower stability. Check lower kit list to ensure the correct stabilisers are fitted.

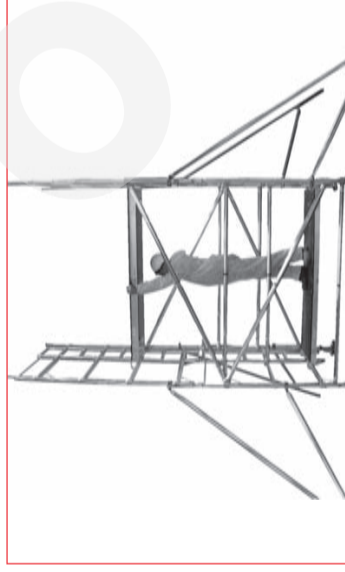

12 Fit trapdoor platform on appropriate rung above your head, see lower illustration guide.



13 From the sitting position through the trapdoor (3T), fit four handrail braces, two on the outside and two on the inside as shown.

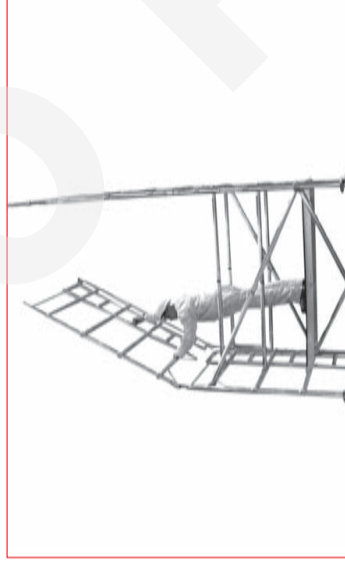

14 Continue erecting tower to final lower height repeating the 3T process as illustrated. Always ensure that there is side protection to prevent falls. Maximum vertical distance between platforms must not exceed 4m.

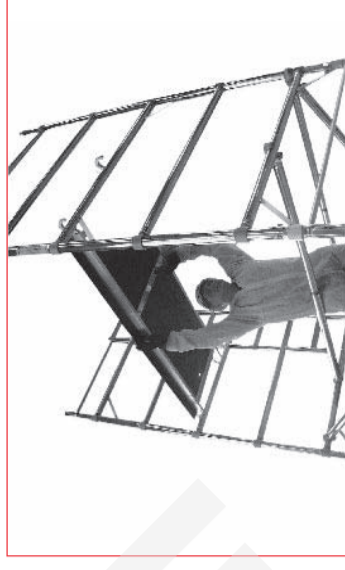

15 Remove plain platform from the bottom and reposition as shown.

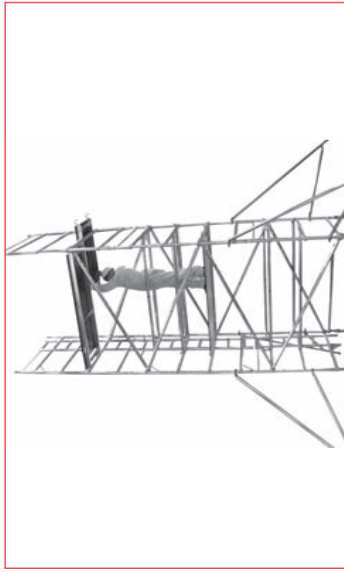

16 Position trapdoor platform alongside plain platform.



17 From the sitting position through the trapdoor (3T), fit four handrail braces to vertical member of frames.

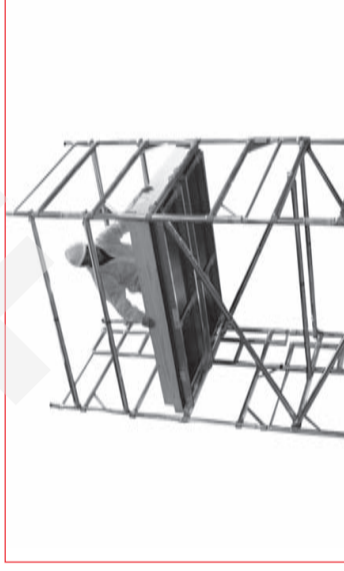

18 When handrails have been correctly fitted, fit toeboards.

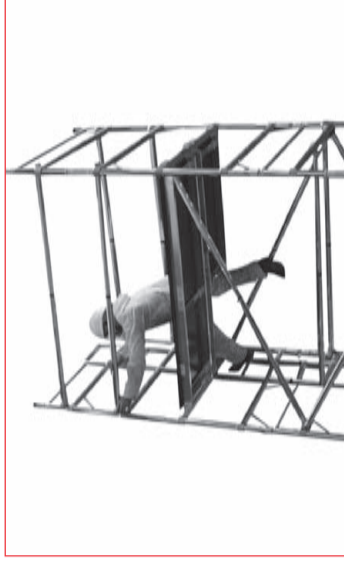

19 Dismantling is the reverse except when dismantling the handrails. Unclip the four end hooks and from the sitting position remove the handrails. Do not remove the handrails whilst standing on the platform, this would leave you at risk.

When INTERMEDIATE PLATFORMS are to be used as working platforms, fit a plain platform beside the trapdoor platform, ensure there are guard rails and midrails on both sides of the tower and that toeboards are used.